

Modular Cooking Range Line EVO900 3-Burner Gas Boiling Top

ITEM # _____

MODEL # _____

NAME # _____

SIS # _____

AIA # _____



392024 (Z9GCGH3C00)

3-concentric burners gas
boiling top (1x5 kW, 1x10 kW,
1x15 kW)

Short Form Specification

Item No. _____

To be installed on open base installations, bridging supports or cantilever systems. 3 high efficiency burners (5 kW, 10 kW and 15 kW) with optimized combustion and protected pilot light. Flame failure device as standard on burners to protect against accidental extinguishing. Exterior panels of unit in stainless steel with Scotch Brite finish. Pan supports in cast iron. Extra strength work top in 20/10 stainless steel.

Main Features

- Unit to be mounted on open base cupboards, bridging supports or cantilever systems.
- The concentric one 5 kW, one 10 kW and one 15 kW high efficiency burners with optimized combustion, flame failure and protected pilot light are supplied in three sizes to suit high performing cooking requirements of the most demanding customers:
 - 60 mm diameter with a power of 5kW
 - 180 mm diameter with a power of 10 kW
 - 350 mm diameter with a power of 15 kW
- Gas appliance supplied for use with LPG gas, conversion jets supplied as standard.
- Large sized pan support in cast iron with long center fins to allow the use of the largest down to the smallest pans.
- Flame failure device on each burner protects against gas leakage when accidental extinguishing of the flame occurs.
- Separate controls for each burner to be ignited based on the size of the paella pan (manual ignition of the top burners).
- The special design of the control knob system guarantees against water infiltration.
- Work top in 20/10 Stainless steel.
- IPX5 water protection.
- Suitable for countertop installation.

Construction

- All exterior panels in Stainless Steel with Scotch Brite finishing.

APPROVAL: _____

Optional Accessories

- Junction sealing kit PNC 206086
- Draught diverter, 150 mm diameter PNC 206132
- Matching ring for flue condenser, 150 mm diameter PNC 206133
- Support for bridge type installation, 800 mm PNC 206137
- Support for bridge type installation, 1000 mm PNC 206138
- Support for bridge type installation, 1200 mm PNC 206139
- Support for bridge type installation, 1400 mm PNC 206140
- Support for bridge type installation, 1600 mm PNC 206141
- Side handrail for right/left hand PNC 206165
- Frontal handrail 800 mm PNC 206167
- Large handrail (portioning shelf) 400 mm PNC 206185
- Large handrail (portioning shelf) 800 mm PNC 206186
- Frontal handrail 1200 mm PNC 206191
- Frontal handrail 1600 mm PNC 206192
- Flue condenser for 1 module, 150 mm diameter PNC 206246
- Ground frame for 3-burner gas boiling top PNC 206283
- Water column with swivel arm (water column extension not included) PNC 206289
- Water column extension PNC 206290
- Chimney upstand, 800 mm PNC 206304
- 2 side covering panels, height 250 mm, depth 900 mm PNC 206321

Front

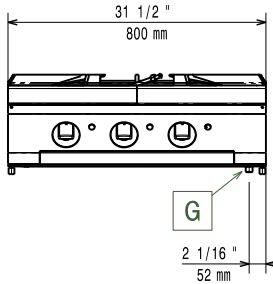

Side

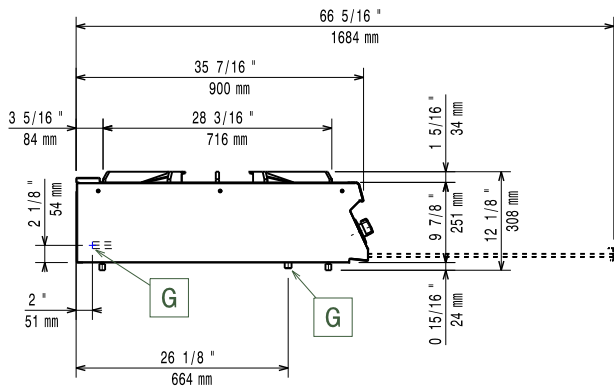

G = Gas connection

Top

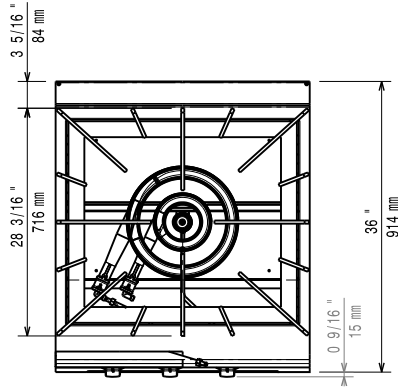

Gas

Gas Power:	
392024 (Z9GCGH3C00)	30 kW
Standard gas delivery:	Natural Gas G20 (20mbar)
Gas Type Option:	LPG
Gas Inlet:	1/2"

Key Information:

Back Burners Power:	5 - 0 kW
Middle Burners Power:	0 - 0/10 - 15 kW
Back Burners Dimension - mm	Ø 60
Middle Burners Dimension - mm	Ø 180 Ø 350
Net weight:	92 kg
Shipping weight:	69 kg
Shipping height:	540 mm
Shipping width:	1020 mm
Shipping depth:	860 mm
Shipping volume:	0.47 m ³
Certification group:	N9PG

If appliance is set up or next to or against temperature sensitive furniture or similar, a safety gap of approximately 150 mm should be maintained or some form of heat insulation fitted.